

# EHPT15-17X-UKHLDW1S

FTC6 **Slimline** Pre-Plumbed Cylinder  
For Ecodan R32 Monobloc Units



## Key Features:

- Unvented plug & play pre-plumbed DHW cylinder
- Efficient & rapid heating
- Premium quality insulation
- Flexible 2-zone space heating control
- MELCloud enabled

## Key Benefits:

- Minimal installation time
- Excellent hot water recovery times
- Reduced heat losses and running costs
- Improved comfort and reduced energy use
- Remote control, monitoring, maintenance and technical support



**MELCloud**



**ecodan**<sup>®</sup>  
Renewable Heating Technology

CYLINDER		EHPT15X-UKHLDW1S		EHPT17X-UKHLDW1S	
NOMINAL HOT WATER VOLUME (LITRES)		150		170	
ErP RATING		C		C	
HEAT LOSS (kWh/24hrs)		1.40		1.59	
HEAT LOSS (W)		58		66	
WATER		Flow Rate (l/min) - WM 50 / 60 / 85		14 / 17 / 24	
		Primary Circuit Pump		Grundfos UPM3L 25-75 130AZA	
		Heating Circuit Pump		Grundfos UPM3 AUTO 25-70 130	
		Sanitary Hot Water Pump		Grundfos UPSO 15-60 CIL2	
		Connection Size (mm) Heating / DHW		22 / 22	
		Charge Pressure (MPa (Bar))		0.35 (3.5)	
WATER SAFETY		Water Circuit		Control Thermistor (°C)	
		DHW Cylinder		DHW Expansion Vessel (Litres)	
				Control Thermistor (°C)	
				Over Temperature Cut-Out (°C)	
				Temp and Pressure Relief Valve (°C) / (MPa (Bar))	
				Expansion Relief Valve (Cold) (MPa (Bar))	
DIMENSIONS (mm)		Width		676	
		Depth		654	
		Height		1516	
WEIGHT EMPTY / FULL (kg)		59/209		63/233	
CYLINDER MATERIAL		Cylinder		Duplex stainless steel	
		Insulation		CFC / HCFC-free flame-retardant expanded Polyurethane	
		Insulation Thickness (mm)		50	
		GWP of Insulation		3.1	
		ODP of Insulation		0	
ELECTRICAL DATA		Control Board - optionally powered by outdoor unit		Electrical Supply	
				Phase	
				Fuse Rating - MCB Sizes (A) <sup>*1</sup>	
		Immersion Heater		Electrical Supply	
				Phase	
				Capacity (kW)	
				Max Running Current (A)	
				Fuse Rating - MCB Sizes (A) <sup>*1</sup>	
MECHANICAL ZONES				DHW and 1 Heating Zone <sup>*2</sup>	
OPTIONAL SIMPLIFIED WIRELESS ROOM THERMOSTAT AND WIRELESS RECEIVER				PAR-WT50-E Controller and PAR-WR51-E Receiver	

<sup>\*1</sup> MCB Sizes BS EN60898-2 & BS EN60947-2 <sup>\*2</sup> Optional 2 zone accessory pack available.

**Notes:** Cylinder includes: Flow Temperature Controller (FTC6) with Main Controller and Temperature Sensors, Magnetic & Cyclonic Filter, Pumps & Valves for Primary Circuit and Zone 1 and DHW use, Flow Sensor, Plate Heat Exchanger, Scale Trap, 3kW Immersion Heater, Expansion Vessel, Diverter Valve and Low Loss Header.

### EHPT15-17X-UKHLDW1S DIMENSIONS

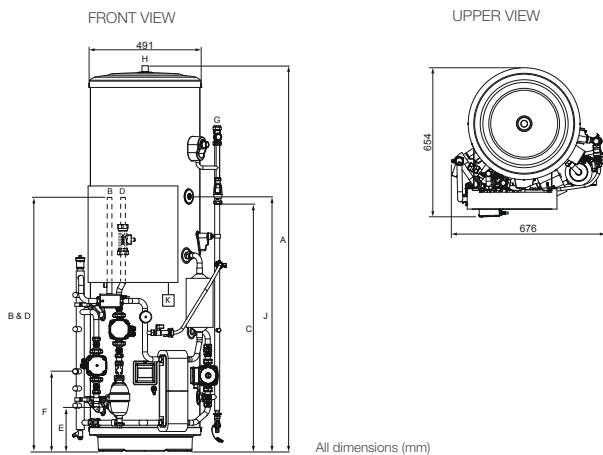

- KEY**
- A OVERALL HEIGHT
  - B HEAT PUMP FLOW CONNECTION (22mm O/D COPPER)
  - C TUNDISH OUTLET CONNECTION (22mm COMPRESSION)
  - D HEAT PUMP RETURN CONNECTION (22mm O/D COPPER)
  - E HEATING ZONE 1 CIRCUIT FLOW CONNECTION (22mm O/D COPPER)
  - F HEATING ZONE 1 CIRCUIT RETURN CONNECTION (22mm O/D COPPER)
  - G COLD WATER INLET CONNECTION (22mm COMPRESSION)
  - H HOT WATER OUTLET CONNECTION (22mm COMPRESSION / 3/4" BSP M)
  - J THWSA SENSOR POCKET
  - K WI-FI ADAPTOR (INCLUDED, INSTALLER TO LOCATE AND MOUNT)

Capacity	150	170
A	1516	1690
B	1127	1127
C	909	1083
D	1127	1127
E	194	194
F	350	350
J	943	1117
K	Installer to locate and mount	



Telephone: 01707 282880  
email: [heating@meuk.mee.com](mailto:heating@meuk.mee.com)  
[ecodan.co.uk](http://ecodan.co.uk)



**UNITED KINGDOM Mitsubishi Electric Europe Living Environment Systems Division**, Travellers Lane, Hatfield, Hertfordshire, AL10 8XB, England. Telephone: 01707 282880 Fax: 01707 278881  
**IRELAND Mitsubishi Electric Europe**, Westgate Business Park, Ballymount, Dublin 24, Ireland. Telephone: (01) 419 8800 Fax: (01) 419 8890 International code: (003531)

Country of origin: United Kingdom - Japan - Thailand - Malaysia. ©Mitsubishi Electric Europe 2022. Mitsubishi and Mitsubishi Electric are trademarks of Mitsubishi Electric Europe B.V. The company reserves the right to make any variation in technical specification to the equipment described, or to withdraw or replace products without prior notification or public announcement. Mitsubishi Electric is constantly developing and improving its products. All descriptions, illustrations, drawings and specifications in this publication present only general particulars and shall not form part of any contract. All goods are supplied subject to the Company's General Conditions of Sale, a copy of which is available on request. Third-party product and brand names may be trademarks or registered trademarks of their respective owners.

**Note:** Refer to 'Installation Manual' and 'Instruction Book' for further 'Technical Information'. The fuse rating is for guidance only and please refer to the relevant databook for detailed specification. It is the responsibility of a qualified electrician/electrical engineer to select the correct cable size and fuse rating based on current regulation and site specific conditions. Mitsubishi Electric's air conditioning equipment and heat pump systems contain a fluorinated greenhouse gas, R410A (GWP:2088), R32 (GWP:675), R407C (GWP:1774), R134a (GWP:1430), R513A (GWP:631), R454B (GWP:466), R1234ze (GWP:7) or R1234yf (GWP:4). \*These GWP values are based on Regulation (EU) No 517/2014 from IPCC 4th edition. In case of Regulation (EU) No.626/2011 from IPCC 3rd edition, these are as follows. R410A (GWP:1975), R32 (GWP:550), R407C (GWP:1650) or R134a (GWP:1300).

Effective as of August 2022

